

**ADCOM**<sup>®</sup>  
*details you can hear*

**GTP-450**

Stereo Tuner/Preamplifier

**OWNER'S MANUAL**

## THE FOLLOWING PRECAUTIONS AND SAFETY INSTRUCTIONS ARE REQUIREMENTS OF UL AND CSA SAFETY REGULATIONS

**Warning: To reduce the risk of fire or electric shock, do not expose this unit to rain or moisture.**

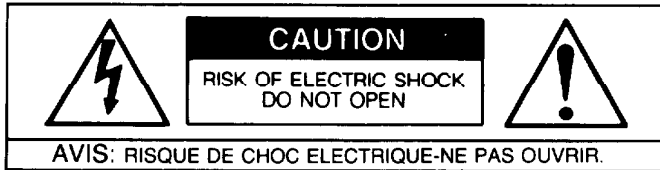

The graphic symbol of a lightning flash with an arrow point within a triangle signifies that there is dangerous voltage within the unit and it poses a hazard to anyone removing the cover to gain access to the interior of the unit. **Only qualified service personnel should make any such attempt.**



The graphic symbol of an exclamation point within an equilateral triangle warns a user of the device that it is necessary to refer to the instruction manual and its warnings for proper operation of the unit.



Do not place this unit on an unstable cart, stand, tripod, bracket, or table. The unit may fall, causing serious injury to a child or adult, and serious damage to the unit. Use only with a cart, stand, tripod, bracket, or table recommended by the manufacturer, or sold with the unit. Any mounting of the device should follow the manufacturer's instructions, and should use a mounting accessory recommended by the manufacturer.

Read all the safety and operating instructions before connecting or using this unit.

Retain this notice and the owner's manual for future reference.

All warnings on the unit and in its operating instructions should be adhered to.

All operating and use instructions should be followed.

Do not use this unit near water; for example, near a bathtub, washbowl, kitchen sink, laundry tub, in a wet basement, or near a swimming pool.

The unit should be installed so that its location or position does not interfere with its proper ventilation. For example, it should not be situated on a bed, sofa, rug, or similar surface that may block the ventilation openings; or placed in a built-in installation, such as bookcase or cabinet, that may impede the flow of air through its ventilation openings.

The unit should be situated away from heat sources such as radiators, heat registers, stoves, or other devices (including amplifiers) that produce heat.

The unit should be connected to a power-supply outlet only of the voltage and frequency marked on its rear panel.

The power-supply cord should be routed so that it is not likely to be walked on or pinched, especially near the plug, convenience receptacles, or where the cord exits from the unit.

Clean unit only as recommended in its instruction manual.

The power-supply cord of the unit should be unplugged from the wall outlet when it is to be unused for a long period of time.

Care should be taken so that objects do not fall, and liquids are not spilled, into the enclosure through any openings.

This unit should be serviced by qualified service personnel when:

- A. The power cord or the plug has been damaged; or
- B. Objects have fallen, or liquid has been spilled, into the unit; or
- C. The unit has been exposed to rain, or liquids of any kind; or
- D. The unit does not appear to operate normally, or exhibits a marked change in performance; or
- E. The device has been dropped, or the enclosure damaged.

**DO NOT ATTEMPT SERVICING OF THIS UNIT YOURSELF.  
REFER SERVICING TO QUALIFIED SERVICE PERSONNEL.**

### ATTENTION

POUR PRÉVENIR LES CHOCS ÉLECTRIQUES NE PAS UTILISER CETTE FICHE POLARISÉE AVEC UN PROLONGATEUR, UNE PRISE DE COURANT OU UNE AUTRE SORTIE DE COURANT, SAUF SI LES LAMES PEUVENT ÊTRE INSÉRÉES À FOND SANS EN LAISSER AUCUNE PARTIE À DÉCOUVERT.

### CAUTION

TO PREVENT ELECTRIC SHOCK DO NOT USE THIS POLARIZED PLUG WITH AN EXTENSION CORD, RECEPTACLE OR OTHER OUTLET UNLESS THE BLADES CAN BE FULLY INSERTED TO PREVENT BLADE EXPOSURE.

### CAUTION POWER LINES

Any outdoor antenna must be located away from all power lines.

### OUTDOOR ANTENNA GROUNDING

If an outside antenna is connected to your tuner or tuner-preamplifier, be sure the antenna system is grounded so as to provide some protection against voltage surges and built-up static charges. Section 810 of the National Electrical Code, ANSI/NFPA No. 70-1984, provides information with respect to proper grounding of the mast and supporting structure, grounding of the lead-in wire to an antenna discharge unit, size of grounding conductors, location of antenna discharge unit, connection to grounding electrodes, and requirements for the grounding electrode.

- a. Use No.10 AWG (5.3 mm<sup>2</sup>) copper, No.8 AWG (8.4 mm<sup>2</sup>) aluminum, No.17 AWG (1.0 mm<sup>2</sup>) copper-clad steel or bronze wire, or larger, as a ground wire.
- b. Secure antenna lead-in and ground wires to house with stand-off insulators spaced from 4-6 feet (1.22-1.83 m) apart.
- c. Mount antenna discharge unit as close as possible to where lead-in enters house.
- d. Use jumper wire not smaller than No.6 AWG (13.3 mm<sup>2</sup>) copper, or the equivalent, when a separate antenna-grounding electrode is used. See NEC Section 810-21 (j).

EXAMPLE OF ANTENNA GROUNDING AS PER NATIONAL ELECTRICAL CODE INSTRUCTIONS CONTAINED IN ARTICLE 810 - RADIO AND TELEVISION EQUIPMENT.

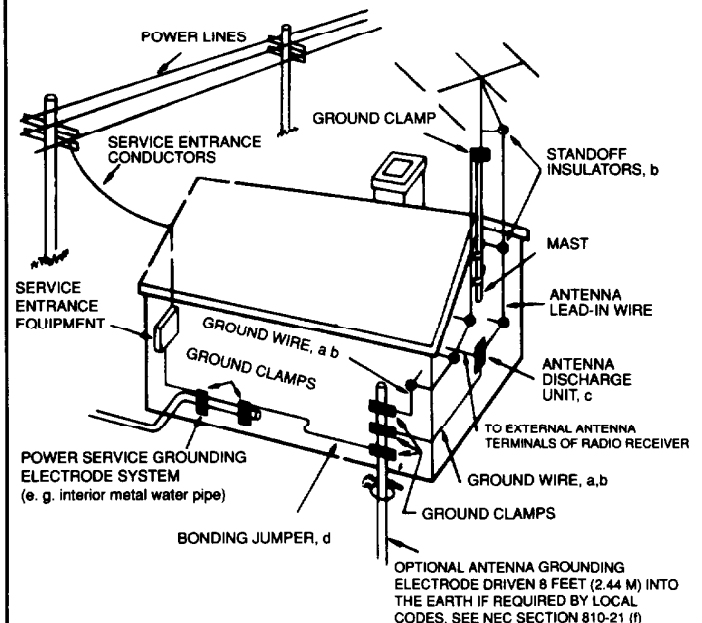

### NOTE TO CATV SYSTEM INSTALLER

This reminder is provided to call the CATV system installer's attention to Article 820-22 of the National Electrical Code that provides guidelines for proper grounding and, in particular, specifies that the cable ground shall be connected to the grounding system of the building, as close to the point of cable entry as practical.

## **INTRODUCTION**

Congratulations on your decision to purchase the ADCOM GTP-450 Stereo Tuner/Preamplifier. You've made a wise choice that will reward you with years of enjoyment.

The GTP-450 is ADCOM's most affordable remote controlled tuner/preamplifier. It combines flexibility, ease of use and ADCOM's almost legendary sound quality. The tuner section uses superbly accurate quartz synthesizer technology for excellent FM and AM reception. The preamplifier section benefits from ADCOM's exclusive linear gain amplifiers and proprietary circuit topology.

The GTP-450 has been engineered as an ideal match for an ADCOM high current power amplifier and allows you to custom tailor a music system to your particular requirements.

Enjoy your music — and thank you!

# FRONT and REAR PANELS

We carefully designed the GTP-450 with your enjoyment in mind. We've arranged the controls in functional groups so that their use is almost intuitive. The rear panel also benefits from the same design goals. Take a few moments to familiarize yourself with them. You'll find references to the circled ID numbers throughout the rest of this manual.

## GTP-450 FRONT PANEL DIAGRAM

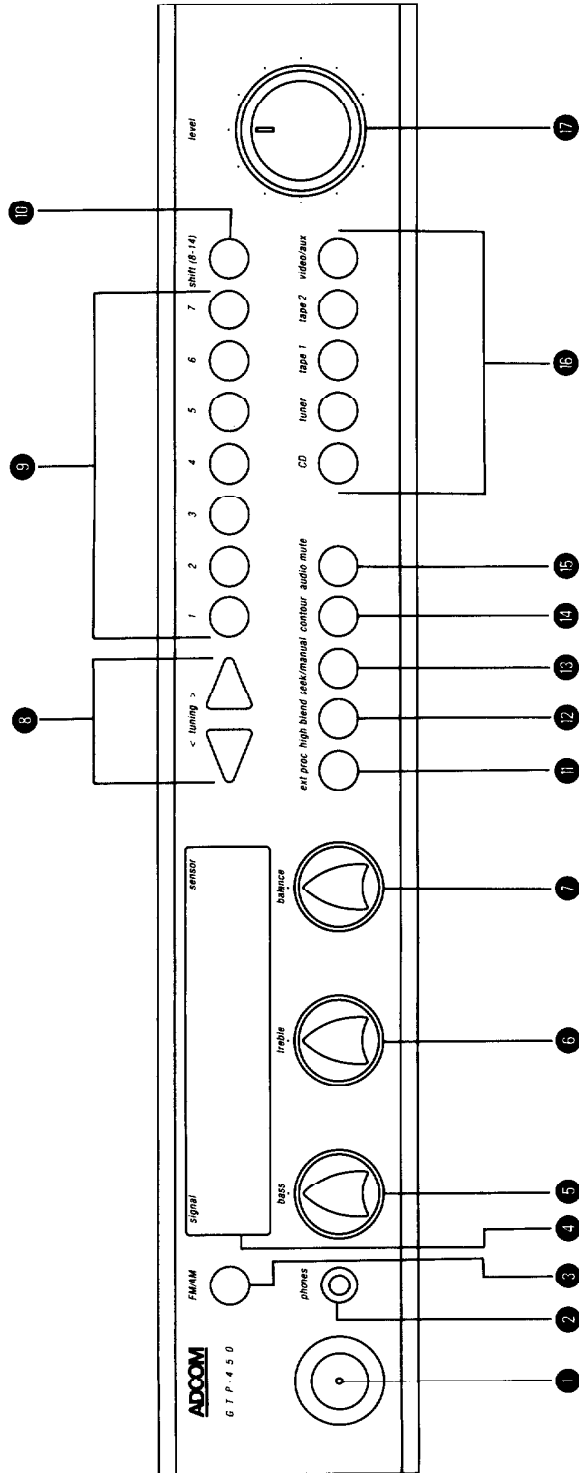

- ① Power On/Off switch with LED indicator
- ② Headphone jack
- ③ FM/AM selector
- ④ Display window
- ⑤ Bass control
- ⑥ Treble control
- ⑦ Balance control
- ⑧ Tuning up/down arrows
- ⑨ Tuner preset buttons
- ⑩ Tuner preset shift button
- ⑪ External processor loop In/Out
- ⑫ FM high blend (mute) On/Off
- ⑬ Seek/manual tuning selector
- ⑭ Contour on/off button
- ⑮ Audio mute On/Off
- ⑯ Input selectors
- ⑰ Volume control



## GTP-450 Remote Control Diagram

- 35 Power On/Off
- 36 Numeric keypad/Tuning selectors
- 37 CD player controls
- 38 Input selectors
- 39 Audio mute On/Off
- 40 Master volume Up/Down

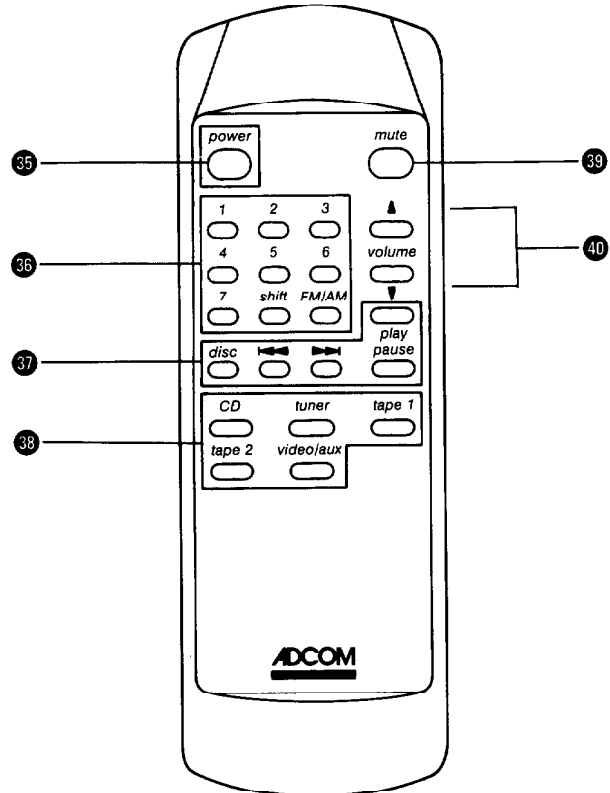

## HOOK UP AND OPERATING INSTRUCTIONS

### OUT OF THE BOX - - -

- 1) **UNPACKING:** Unpack the GTP-450 carefully. Put the foam inserts and other packing materials back in the carton and save them.

As part of ADCOM's quality control procedures, your GTP-450 was carefully inspected for physical imperfections and electrical performance before it left our plant. In the event of physical damage, notify your ADCOM dealer immediately and request help in filing a written damage claim.

THE RIGHT TO A CLAIM AGAINST A COMMON CARRIER CAN BE FORFEITED IF THE CARRIER IS NOT NOTIFIED PROMPTLY IN WRITING AND IF THE SHIPPING CARTON AND PACKING MATERIALS ARE NOT AVAILABLE FOR INSPECTION. SAVE ALL PACKING MATERIALS UNTIL THE CLAIM HAS BEEN SETTLED.

The foam packing and carton were specifically designed to protect your GTP-450. Even though space is often at a premium in today's homes, we recommend that you save the packing material in case you need to ship the unit in the future.

- 2) **PLACEMENT:** Select a stable, vibration-free location for the GTP-450 as close as possible to your other audio and video components. The more massive and firmly anchored the supporting surface is, the less likely you'll be to experience any problems.
- 3) **POWER OFF:** Turn off all the other components in your system. This means everything. And don't plug the GTP-450 into the AC outlet yet.

Remember to give any power amplifiers sufficient time to fully discharge their power supplies before you begin your connections: 30 seconds after turn-off is usually sufficient.

## CONNECTIONS

- 4) **FM ANTENNA:** Depending on the antenna you use, connect it to either the **75 Ohm terminal 19** or the **300 Ohm screw terminals 20** on the GTP-450's rear panel.

The "T" shaped FM antenna supplied with the GTP-450 is a 300 ohm "dipole" and should be connected accordingly.

The supplied antenna will probably be adequate for most installations. After you've connected the rest of your system and turned it on, select Tuner by pushing the **Tuner input selector 3**. Then choose FM by pressing the **FM/AM selector 3** if necessary. Tune to an FM station. Extend the top of the "T" antenna and rotate it to the position that results in the best reception. Once you've determined the optimum position, fasten the antenna to the wall, a cabinet back or even the ceiling so that the "T" is aligned in the direction that gave you the best reception.

Remember that the dipole antenna is directional — it is most sensitive to signals arriving at right angles to the extended "T" and relatively insensitive to signals arriving from the ends of the "T."

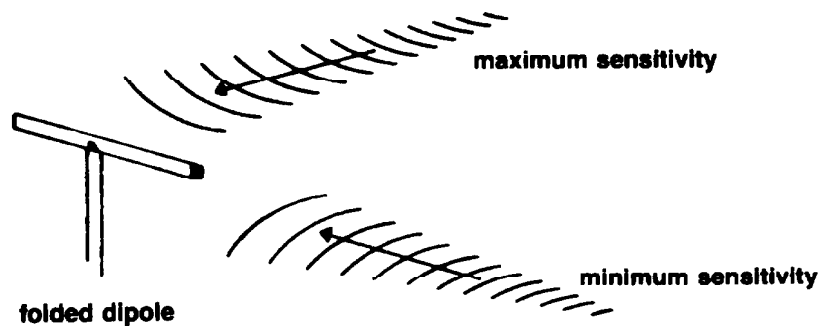

Any dipole antenna rapidly loses its effectiveness when rolled up or carelessly dropped behind a cabinet, etc. If the "T" antenna is undesirable from a performance or aesthetic point of view, your ADCOM dealer will be pleased to show you a variety of indoor antennas that might be more appropriate. We do suggest, however, that you ask for a home trial as reception conditions vary enormously from location to location.

The GTP-450 can also be used with a 75 ohm antenna. These are usually large roof mounted antennas and can provide superior reception when compared to the 300 ohm "dipole." In addition, most cable companies use 75 ohm cable to distribute FM signals. Connect the GTP-450 to a 75 ohm antenna system by terminating the connecting cable with an "F" connector (available at most electronic parts stores) and attaching it to the rear panel **75 ohm antenna terminal 19**.

The grounding schemes used by cable companies are very complex and occasionally cause hum when the cable is attached to the 75 ohm antenna input. An isolation transformer (again, available at most electronic parts stores) will usually solve the problem.

- 5) **AM ANTENNA:** Connect the supplied AM antenna to the "Ground" and "AM" screw terminals **21** on the GTP-450's rear panel. It does not matter which screw you connect each antenna lead to as there is no proper "polarity" to observe.

The supplied movable ferrite "loop" antenna will provide reasonable AM reception in most locations. The loop should be rotated away from the body of the GTP-450 and some experimentation will undoubtedly improve AM reception.

In the event that you need better reception, you can make your own AM antenna from a single length of insulated wire. Connect one end of the wire to the terminal marked "AM" and run the other end to a high location in your home or hang it from a window.

In most cases, a second wire run from the "Ground" terminal to a solid earth ground (a cold water pipe for example) will also improve AM reception as well as provide a safe "path to ground" in the event that lightning strikes an outdoor AM antenna.

- 6) AUDIO SOURCE HOOK UP:** Connect up to four external high level audio sources (CD players, the audio outputs of VCRs, cassette decks, MD or DCC devices, etc.) to the appropriate inputs (22, 23, 24 and 26) on the rear panel. Be sure to observe proper channel continuity (Left channel to Left channel, Right to Right).

The line inputs of up to two recording devices should be connected to the GTP-450's corresponding tape outputs (25 and 27).

Patience and common sense will help you avoid almost all the errors you might make when rushing the initial installation. Remember that "outputs" are always connected to "inputs" and that channel continuity (left channel to left channel and right channel to right channel) is very important. For example, the left and right channel "output" jacks on a CD player should be connected to the CD "input" jacks on the GTP-450. The "output" jacks of your primary tape recorder should be connected to the GTP-450's Tape 1 "input" jacks while the recorder's "input" jacks are connected to the GTP-450's Tape 1 "output" jacks.

The jacks on all ADCOM products follow conventional color coding: White for Left channel and Red for Right channel. Most interconnect cables observe this general guideline: The connectors on each end of the cable are usually color coded.

We've received many questions about the sonic attributes of premium interconnect cables. We do suggest that you make sure any cable you use is a "low capacitance" design. (Most are.) Your ADCOM salesperson will be happy to make cost-effective recommendations based on individual component characteristics and system complexity.

- 7) PREAMP TO POWER AMP CONNECTIONS:** Connect the GTP-450's Main preamp outputs (30) to the corresponding power amplifier inputs. Remember to maintain proper channel continuity: Connect the GTP-450's Right output to the power amplifier's Right input, etc.

**8) AC CONVENIENCE OUTLETS** (Certain models only)

- A) Switched outlet: This outlet (32) supplies AC current whenever the GTP-450 is "ON" (provided, of course, that the GTP-450 itself is plugged into a live AC outlet).

Make sure that the component plugged into this outlet does not draw in excess of 500 watts (VA). You'll find the power consumption of most components marked on the rear panel near the power cord or model number identification.

- B) Unswitched outlet: This outlet (33) supplies AC whenever the GTP-450 is plugged into a live AC outlet regardless of whether the GTP-450 is "ON" or not. The unswitched outlet is usually reserved for mechanical devices (a tape deck, for example) that might be damaged if power is inadvertently cut off before the mechanism disengages.

Make sure that the component plugged into the Unswitched outlet does not draw in excess of 800 watts (VA). Remember that large power amplifiers can impose substantial demands on any electrical outlet, especially during "turn on."

We strongly recommend the use of ADCOM's ACE-515 AC line enhancer/sequential switcher. In addition to providing the convenience and safety of surge protected multiple outlets and dramatically superior RF and EMI filtering, the ACE-515 simplifies system turn-on and turn-off as well. Time delay switching protects your speakers from the potentially annoying effects of power transients. Check with your ADCOM dealer for details.

- 9) AC LINE FUSE:** This socket (31) holds the AC line fuse. In the unlikely event that the AC fuse opens, replace it ONLY with a fuse of the exact type and rating. A higher rating or different fuse type will not protect the GTP-450, will void the warranty and may be a fire hazard!

This fuse DOES NOT PROTECT the AC convenience outlets.

A subsequent fuse failure means that your GTP-450 needs service.

- 10) AC LINE CORD:** Plug the AC cord (34) into a power source (wall outlet, line enhancer, etc.) supplying the correct voltage for your unit. Check the rear panel label to make sure that your unit is designed for the available voltage. For example, units for use in the U.S. are set for 110 to 125 VAC, 50/60 Hz.

We strongly suggest an unswitched power source so that power to the GTP-450 can't be accidentally interrupted by turning off an external AC switch.

If the GTP-450 is without AC power for an extended period of time, usually longer than 48 hours, station memory may be affected.

## OPERATION

NOTE: This section assumes that you've set up the rest of your system (sources, power amplifiers and speakers, etc.) in accordance with the instructions supplied with these units.

- 11) VOLUME DOWN — POWER ON:** Turn the GTP-450's **volume control** ⑰ all the way down (fully counterclockwise). Turn the unit on by pressing the **power switch** ①. Then turn the other system components on; sources first, then power amplifiers. This helps avoid unintentional initial high sound levels.

Note that the LED in the power switch is amber colored whenever the GTP-450 is plugged into a live AC outlet even when the unit itself is turned off. The LED will turn red as soon as the unit is turned on.

- 12) SOURCE SELECTION and RECORDING:** Choose a source to listen to by using the **Input Selectors** ⑯. Then operate the source component according to the supplied instructions.

The signal from any selected source is always available at both rear panel tape outputs (⑳ & ㉑) for convenient recording. The only exception to this occurs when you select either Tape 1 or Tape 2 as a source. When you do this, the output from your choice IS NOT routed to the corresponding input. For example, when you select Tape 1 as a source, the signal from the Tape 1 input does not appear at the Tape 1 output. (The signal is still available at the Tape 2 output, however). This prevents the creation of an undesirable feedback loop that might damage amplifiers or speakers.

- 13) THE TUNER:** The Tuner section is responsible for processing and amplifying extremely weak signals "pulled in" by the appropriate antenna. ADCOM's refined quartz synthesis technology makes this a highly accurate exercise. However, using the tuner is a simple process.

A) The Display window ④ provides an instant status check of the following important items:

- 1) AM & FM signal strength: Up to five red LEDs on the left hand side of the display will light depending on signal strength. This display can help you find the best location for your antenna — the more LEDs showing, the stronger the signal.
- 2) Stereo indicator: This operates in FM mode only and lights whenever the tuner circuit senses the presence of a "subcarrier" signal necessary for stereo reception.
- 3) FM/AM band/frequency indicator: This is displayed at the center of the window.
- 4) FM "Seek" mode indicator: Appears immediately above the "MHz" indicator. Note that **Seek** does not function in AM. (See Section B2 below.)
- 5) Preset indicator: Located on the far right hand side of the display, this lights when one of the pre-programmed stations is chosen.

B) After selecting FM or AM with the FM/AM selector ③, tune to the desired station by one of the following methods:

- 1) Press one of the Tuning up/down arrows ⑧ until the **Display** ④ shows the proper station frequency.
- 2) Enter "Seek" mode (FM only) by pressing the **Seek/manual** button ⑬. "Seek" appears in the display. Then press either of the **Tuning up/down** arrows ⑧. The GTP-450 will automatically advance to the next active broadcast frequency with a strong signal.
- 3) Press any of the Tuner Preset buttons ⑨ to recall preprogrammed station frequencies. Of course, this works only after you've programmed your favorite stations. Here's how:
  - a) Tune to the desired broadcast frequency by using either of the two methods outlined in B1 or B2 above.
  - b) Decide what preset # you want to assign to that frequency.
  - c) Hold down the desired **tuner preset button** ⑨ until the word "preset" and the corresponding number appears on the right hand side of the display.

Note that preset positions 1 through 7 are memorized and accessed directly — simply push the button with the corresponding number.

To memorize and access presets 8 through 14, press the **Shift** button ⑩ and then a preset button. For example, if you want preset number 11, press **Shift** and then press **Preset 4** (7+4=11). If you want preset number 8, press **Shift** and **Preset 1** in that order (7+1=8).

All preset numbers are "random" in that you can assign any preset number to any FM or AM signal. In other words, preset 1 can be AM, presets 2-4 can be FM, preset 5 can be AM, etc.

- C) The **High blend** button 12 can reduce the background noise sometimes encountered on weaker stereo FM signals.

The High Blend circuit reduces high frequency channel separation by mixing (or "blending") these frequencies.

Due to the technicalities of FM broadcasting, this high frequency blend also reduces background noise, sometimes by a substantial amount. You'll have to experiment to determine the exact effect in your reception area as it will depend on many factors, including your antenna.

The **High blend** button also controls the FM Mute circuit. The FM Mute circuit decreases the tuner's sensitivity to very weak signals that are not usually strong enough for proper reception. It also blocks the annoying interstation noise often encountered when tuning from one broadcast to another. As far as the FM Mute circuit is concerned, interstation noise is just one more weak signal!

If you wish to receive a very weak or very distant FM broadcast, press the High blend button to disengage the FM Mute circuit and then tune in the desired frequency.

- 14) TONE CONTROLS:** The **Bass** and **Treble** controls (5 & 6 respectively) emphasize or decrease low and high frequencies to suit your taste.

ADCOM's tone controls are far more subtle than similar controls on competitive units. While conventional controls affect large portions of the midrange in addition to either bass or treble, ADCOM's circuits affect only the frequency extremes and leave the critical midrange virtually untouched. The benefit is that musical clarity is unchanged even when you select large amounts of tonal compensation.

- 15) CONTOUR ON/OFF CONTROL:** The **Contour** button 14 engages a circuit that compensates for the fact that we don't hear low frequencies (bass notes) as easily at low volume levels as we do at higher volume settings. Based on the most recent research by Robinson and Dadson at Harvard University, this circuit subtly boosts low bass information (between 20 and 100 Hz) and leaves high frequency content unaffected. This provides the ideal balance for listening to music at low to moderate levels. This circuit has progressively less effect as you raise the volume control.

- 16) BALANCE CONTROL:** The **balance control** 7 adjusts for unequal volume levels between the left and right channels. If you want more output from the right speaker, for example, turn the control to the right.

The final position of the balance knob will vary depending on eccentricities in the source, room acoustics and your listening position.

- 17) VOLUME CONTROL:** This rotary control 17 sets the level at both the **headphone jack** 2 and the **Main preamp output** 30 for whatever source you have selected. Thus, it is responsible for the volume of sound heard through both headphones and speakers.

The useful range of this control will vary depending on the output of the source, the power amplifier's input sensitivity, the loudspeakers' efficiency, and other factors. In other words, the amount of rotation needed for a certain volume level is dependent on other system parameters and has relatively little to do with "system power."

Be aware that you may want to change the setting of the volume control when you select a different source (i.e., "CD" may be louder than "Tape.") This is entirely natural and is due to the different output levels of your various sources. Simply raise or lower the volume control to compensate.

When you're not using headphones, disconnect them from the phones jack to avoid an inadvertent "over-drive" condition when playing speakers loudly. Conversely, you may want to turn off your power amplifier (or switch the speakers off) when using headphones. This avoids irritating the neighbors or other family members when playing music loudly through the headphones.

The LED located on the outer edge of the knob's front surface glows steadily during normal operation. When **Audio mute** 15 is engaged, the LED flashes at 0.5 second intervals as a reminder. CAUTION: Do not disengage **Audio mute** while the **Volume control** is set higher than approximately 10 o'clock.

- 18) AUDIO MUTE CONTROL 15:** This control fully mutes the GTP-450's main outputs. This is in contrast to competitive circuits that simply reduce the output by an arbitrary fraction. This conventional approach is

problematic in that our ears perceive loudness in a relative rather than an absolute way. Circuits that simply reduce gain have a different subjective effect depending on the original position of the volume control: ADCOM's infinite attenuation circuit has the same subjective effect at any volume control position.

#### **19) THE REMOTE CONTROL:**

The keys of the RC-45 II are divided into 4 groups:

- a) Basic functions: Power On/Off, Audio Mute On/Off and Volume Up/Down.
- b) Tuner-specific functions: Preset selectors (keys numbered 1 through 7,) the Shift key (to access presets 8 through 14) and the AM/FM selector key. These keys are grey on a grey background.
- c) CD-specific functions: Disc select (to change discs in a multidisc player,) Track-Back and Track-Forward (to select the previous or next track on a disc,) Play and Pause. These black keys are on a green background.
- d) Input selectors: These keys select the desired audio or audio/video input and are grey on a grey background.

### **CARE AND FEEDING OF THE GTP-450**

ADCOM has taken great care to assure that your GTP-450 is as flawless in appearance as it is electrically. The front panel is a heavy-gauge, high grade anodized aluminum extrusion bead blasted for durability. The chassis, rear panel and top cover are painted and baked heavy gauge steel.

If the outer cover or front panel becomes dusty or fingerprinted, please clean with a soft, lintless cloth SLIGHTLY DAMPENED with a very mild detergent solution.

**DO NOT SPRAY OR USE LIQUIDS OF ANY KIND ON YOUR UNIT!**

**NEVER USE HARSH SCOURING POWDERS!**

### **SERVICING**

ADCOM's Technical Service Department will be happy to answer all questions pertaining to the installation and operation of your unit. In the unlikely event of difficulty, please contact us for prompt advice. If we can't help you resolve the problem immediately, we may refer you to an authorized repair agency, or authorize the return of your unit to our plant.

All written inquiries should be addressed to:

**ADCOM Service Department  
10 Timber Lane  
Marlboro, NJ 07746  
USA**

Telephone inquiries are welcomed from Monday through Friday between 9 AM and 4 PM, Eastern Time.

Please call (908) 390-1130

We'll also be happy to answer FAX inquiries sent to (908) 390-9152. Please include your phone and FAX numbers so we can respond.

When inquiring about your unit, please include the serial number, the name of the dealer from whom you purchased the unit and the date of purchase.

If we ask you to return the unit to us for service, we will issue a specific Return Authorization number for your use. **UNDER NO CIRCUMSTANCES SHOULD THE UNIT BE SHIPPED TO US WITHOUT PROPER AUTHORIZATION OR PACKED IN ANYTHING OTHER THAN ITS ORIGINAL PACKING.**

If the original packing has been lost, discarded or damaged, we will be happy to supply a replacement at a nominal charge. Please mention your need when you call or write.

Always ship PREPAID via UPS (United Parcel Service) or other appropriate carrier. **FREIGHT COLLECT SHIPMENTS WILL BE REFUSED.**

**DO NOT SHIP VIA PARCEL POST** as the packaging will not necessarily withstand handling by our Postal Service.

# GTP-450 SPECIFICATIONS

## Preamplifier Section

<b>Output Impedance</b>	
Main Outputs .....	475Ω
Tape Outputs .....	500Ω
<b>Output Level (Rated)</b> .....	1.0V
<b>Input Impedance</b> .....	25kΩ
<b>Frequency Response</b>	
20Hz to 20kHz .....	±1/2dB
<b>THD+N @ Rated Output</b>	
20Hz to 20kHz .....	≤0.0075%
<b>IM Distortion</b>	
SMPTE .....	≤0.009%
CCIF from 4kHz to 20kHz .....	≤0.005%
<b>Signal to Noise Ratio (Ref. to 1 volt)</b>	
“A” Weighted .....	≥95dB
<b>Tone Controls</b>	
Bass .....	±12dB
Treble .....	±8dB

## FM Tuner Section

<b>Usable Sensitivity (Mono)</b> .....	3 μV / 15 dBf
<b>Quieting Sensitivity (50dB)</b>	
Mono .....	3.4 μV / 22 dBf
Stereo .....	31 μV / 41 dBf
<b>Signal To Noise (65dBf, “A” weighted)</b>	
Mono .....	78 dB
Stereo .....	67 dB
<b>THD+N (1kHz, 65dBf)</b>	
Mono .....	0.085%
Stereo .....	0.095%
<b>Capture Ratio</b> .....	2.5dB
<b>Alternate Channel Selectivity (± 400kHz)</b> .....	≥75dB
<b>Separation (@1kHz)</b> .....	≥50dB
<b>Frequency Response (±0.5dB)</b> .....	30Hz to 15kHz

## AM Tuner Section

<b>Sensitivity</b> .....	300μV/m
<b>Selectivity (±10kHz)</b> .....	> 40dB
<b>Signal To Noise (5mV/m “A” Weighted)</b> .....	≥45dB

## General

<b>Power</b> (available in 220V or 240V on special order) .....	120VAC/50-60Hz
<b>Chassis Dimensions</b> .....	3"(76mm) x 17"(432mm) x 11 1/2"(292mm)
<b>Maximum Dimensions</b> .....	3 1/4"(83mm) x 17"(432mm) x 12 3/4"(324mm)
<b>Weight</b> .....	14 lbs. (6.3kg)
<b>Weight, Packed</b> .....	16.5 lbs. (7.5kg)

## ADCOM

10 Timber Lane  
Marlboro, NJ 07746 U.S.A.  
Tel: (732) 683-2356  
Fax: (732) 683-9792  
www.adcom.com