



GFA-7000

**High Current THX[®]
5-Channel
Power Amplifier**



OWNER'S MANUAL

THE FOLLOWING PRECAUTIONS AND SAFETY INSTRUCTIONS ARE REQUIREMENTS OF UL AND CSA SAFETY REGULATIONS

Warning: To reduce the risk of fire or electric shock, do not expose this unit to rain or moisture.

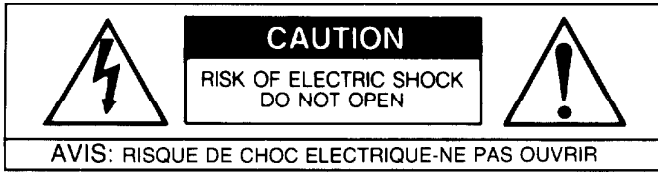

The graphic symbol of a lightning flash with an arrow point within a triangle signifies that there is dangerous voltage within the unit and it poses a hazard to anyone removing the cover to gain access to the interior of the unit **Only qualified service personnel should make any such attempt.**



The graphic symbol of an exclamation point within an equilateral triangle warns a user of the device that it is necessary to refer to the instruction manual and its warnings for proper operation of the unit



Do not place this unit on an unstable cart, stand, tripod, bracket, or table. The unit may fall, causing serious injury to a child or adult, and serious damage to the unit. Use only with a cart, stand, tripod, bracket, or table recommended by the manufacturer, or sold with the unit. Any mounting of the device should follow the manufacturer's instructions, and should use a mounting accessory recommended by the manufacturer

Read all the safety and operating instructions before connecting or using this unit

Retain this notice and the owner's manual for future reference

All warnings on the unit and in its operating instructions should be adhered to

All operating and use instructions should be followed

Do not use this unit near water, for example, near a bathtub, washbowl, kitchen sink, laundry tub, in a wet basement, or near a swimming pool

The unit should be installed so that its location or position does not interfere with its proper ventilation. For example, it should not be situated on a bed, sofa, rug, or similar surface that may block the ventilation openings, or placed in a built-in installation, such as bookcase or cabinet, that may impede the flow of air through its ventilation openings

The unit should be situated away from heat sources such as radiators, heat registers, stoves, or other devices (including amplifiers) that produce heat

The unit should be connected to a power-supply outlet only of the voltage and frequency marked on its rear panel

The power-supply cord should be routed so that it is not likely to be walked on or pinched, especially near the plug, convenience receptacles, or where the cord exits from the unit

Clean unit only as recommended in its instruction manual

The power-supply cord of the unit should be unplugged from the wall outlet when it is to be unused for a long period of time

Care should be taken so that objects do not fall, and liquids are not spilled, into the enclosure through any openings

- This unit should be serviced by qualified service personnel when
- A The power cord or the plug has been damaged, or
 - B Objects have fallen, or liquid has been spilled, into the unit, or
 - C The unit has been exposed to rain, or liquids of any kind, or
 - D The unit does not appear to operate normally, or exhibits a marked change in performance, or
 - E The device has been dropped, or the enclosure damaged

**DO NOT ATTEMPT SERVICING OF THIS UNIT YOURSELF.
REFER SERVICING TO QUALIFIED SERVICE PERSONNEL.**

ATTENTION

POUR PRÉVENIR LES CHOCS ÉLECTRIQUES NE PAS UTILISER CETTE FICHE POLARISÉE AVEC UN PROLONGATEUR, UNE PRISE DE COURANT OU UNE AUTRE SORTIE DE COURANT, SAUF SI LES LAMES PEUVENT ÊTRE INSÉRÉES À FOND SANS EN LAISSER AUCUNE PARTIE À DÉCOUVERT

CAUTION

TO PREVENT ELECTRIC SHOCK DO NOT USE THIS POLARIZED PLUG WITH AN EXTENSION CORD, RECEPTACLE OR OTHER OUTLET UNLESS THE BLADES CAN BE FULLY INSERTED TO PREVENT BLADE EXPOSURE

CAUTION

POWER LINES

Any outdoor antenna must be located away from all power lines.

OUTDOOR ANTENNA GROUNDING

If an outside antenna is connected to your tuner or tuner-preamplifier, be sure the antenna system is grounded so as to provide some protection against voltage surges and built-up static charges. Section 810 of the National Electrical Code, ANSI/NFPA No. 70-1984, provides information with respect to proper grounding of the mast and supporting structure, grounding of the lead-in wire to an antenna discharge unit, size of grounding conductors, location of antenna discharge unit, connection to grounding electrodes, and requirements for the grounding electrode.

- a. Use No.10 AWG (5.3 mm²) copper, No.8 AWG (8.4 mm²) aluminum, No.17 AWG (1.0 mm²) copper-clad steel or bronze wire, or larger, as a ground wire.
- b. Secure antenna lead-in and ground wires to house with stand-off insulators spaced from 4-6 feet (1.22-1.83 m) apart.
- c. Mount antenna discharge unit as close as possible to where lead-in enters house
- d. Use jumper wire not smaller than No.6 AWG (13.3 mm²) copper, or the equivalent, when a separate antenna-grounding electrode is used. See NEC Section 810-21 (j).

EXAMPLE OF ANTENNA GROUNDING AS PER NATIONAL ELECTRICAL CODE INSTRUCTIONS CONTAINED IN ARTICLE 810 - RADIO AND TELEVISION EQUIPMENT

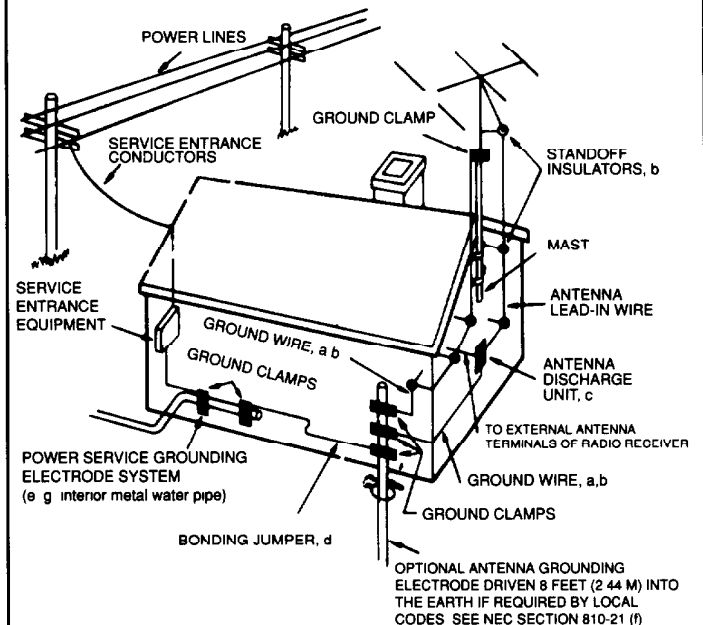

NOTE TO CATV SYSTEM INSTALLER

This reminder is provided to call the CATV system installer's attention to Article 820-22 of the National Electrical Code that provides guidelines for proper grounding and, in particular, specifies that the cable ground shall be connected to the grounding system of the building, as close to the point of cable entry as practical

GFA-7000 FEATURES

- Precision-matched devices used throughout the signal path.
- 120,000 μ F of power supply-filter capacitance for greater reserve capacity.
- Independent power supplies for each channel.
- Fewer gain stages improve signal reproduction accuracy.
- Custom toroidal power transformer provides better regulation and greater peak current capability.
- Independent thermal-overload and distortion LEDs for all 5 channels.
- High quality, gold-plated 5-way binding posts.
- High quality, gold-plated RCA jacks.
- Large independent, internal heatsinks for greater cooling capability of output devices.
- Heavy gauge, anodized aluminum front panel.
- Powder-coated, baked chassis and top cover for greater durability.
- Cooling vents for greater efficiency and cooler operation while driving low impedance loads.
- Home THX[®] standard DB-25 connector to simplify installation
- Made in the USA

TABLE OF CONTENTS

INTRODUCTION

WHAT IS HOME THX [®] ?	2
WARRANTY INFORMATION	2

DESCRIPTION OF UNIT

REAR PANEL	3
FRONT PANEL.....	5

INSTALLATION & HOOKUP

UNPACKING THE GFA-7000	7
PLACING THE GFA-7000	7
QUICK CONNECTION DIAGRAM.....	8
CONNECTING THE GFA-7000	9
CARING FOR YOUR GFA-7000	10

TROUBLESHOOTING

RESOLVING PROBLEMS	11
SERVICE INFORMATION	12
SPECIFICATIONS	13



THX[®], and Home THX[®] are registered trademarks of Lucasfilm Ltd

Dolby ProLogic[®] and Dolby AC-3[®] are registered trademarks of Dolby Laboratories Licensing Corp

INTRODUCTION

Congratulations on your decision to purchase the GFA-7000, Home THX[®] certified, 5-channel power amplifier. Not only is the GFA-7000 certified for Home THX[®] systems, but it will also integrate with any other home theater system, such as Dolby ProLogic[®] or Dolby AC-3[®]. You have made a wise choice that will reward you with exceptionally accurate and musical sound reproduction for years to come. To realize the full potential of your new amplifier, please read these operating and installation instructions thoroughly before attempting to make any connections to it.

WHAT IS HOME THX[®] ?

Home THX[®] is the system developed by Lucasfilm Ltd. to maximize the accuracy of film soundtracks in a home environment. It is important as soundtracks and their related special effects become a greater and greater part of the whole film viewing and listening experience.

In order for a component to display the Home THX[®] system mark, it has to conform to the strict series of standards that were investigated and defined during the 1980's by Tom Holman of Lucasfilm Ltd. A home theater surround system utilizing Home THX[®] certified components throughout, will give the most accurate re-creation of the original sound tracks put on the film in the creative "dubbing stage" by its director, conductor and sound designer. Approved Home THX[®] components insure all the necessary improvements to deliver the intended effects of a film in home theater sound reproduction. The benefits are:

- Clearer dialog
- Precise front-stage sound localization
- Expanded depth of the sound field
- Extended and smooth frequency response
- Wider dynamic range
- Smoother sound transition among channels

The Adcom GFA-7000 amplifier is designed not only to meet these standards, but to exceed them and deliver the most accurate reproduction of Home THX[®]-encoded films.

ADCOM PROTECTION PLAN (USA ONLY)

ADCOM offers the enclosed valuable Limited Warranty. Please read the details on the Warranty Card carefully to understand the extent of the protection offered by the Warranty, its reasonable limitations, and what you should do in order to obtain its benefits. Be sure to verify that the serial number printed on the rear panel matches the serial number on the outer carton. If any number is altered or missing, you should notify us immediately in order to ensure that you have received a genuine ADCOM product which has not been opened, mishandled, or tampered with in any way. **Always retain your original sales receipt as a proof of purchase.**

DESCRIPTION OF UNIT

REAR PANEL

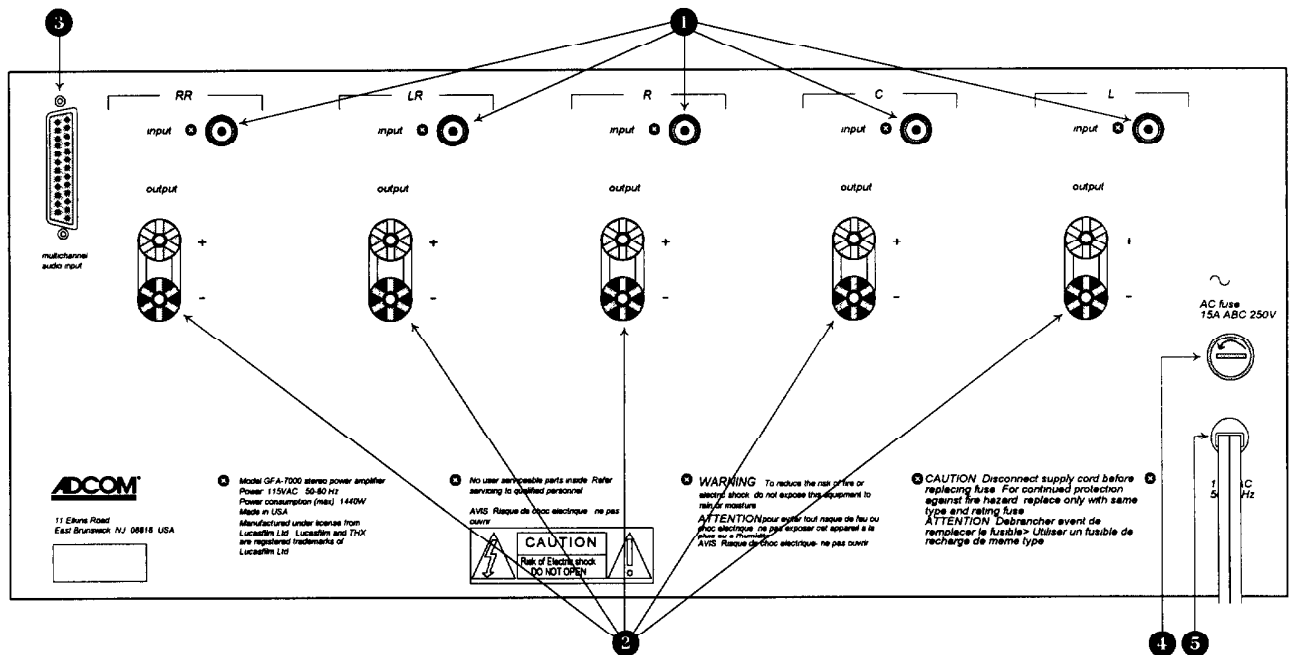

❶ RR, LR, R, C, L Inputs

The audio inputs for the GFA-7000 are through high-quality, gold-plated RCA jacks to minimize high-frequency losses, noise, etc. They will accept standard RCA-type plugs, one for each of the five channels; Left (L), Center (C), Right (R), Left Rear (LR), and Right Rear (RR). To insure that the performance designed into the GFA-7000 is preserved, you should use the highest quality audio cables possible. There are many cables which are Home THX® certified, color-coded and specifically designed for this application. Your Adcom dealer can help select the best cable for your needs. (See **CONNECTING THE GFA-7000** for more information).

❷ RR, LR, R, C, L Outputs

The GFA-7000's connections to the loudspeakers are made through high-grade, 5-way, gold-plated binding post terminals. There are two terminals for each speaker, which are colored RED for the positive (+) output and BLACK for the negative (-) output.

The binding posts will accept a variety of connector types; the most secure and prevalent of these is the "U"-type spade connectors (at least 0.25" wide and maximum width of 0.57"),. The terminal will also accept bare wire (up to AWG10) and "banana" type plugs (single or dual). Pin connectors are not recommended for use with Home THX® equipment. (See **CONNECTING THE GFA-7000** for more information).

❸ DB-25 Multichannel Audio Input Connector

Input connections may be made with the optional DB-25 computer-type connector, which is a Home THX® certified option when your Home THX® controller is provided with a similar output connector. Using this type of connecting cable would override the need to use the RCA-type inputs (❶). This mode of connection retains the same high level of signal transfer, simplifies the job significantly and insures automatic, correct connections to all channels.

④ AC Fuse

The AC Fuse protects the electronic circuits of the GFA-7000. This fuse, normally, will blow only if there is an overload within the GFA-7000. It may, however, blow if the amplifier attempts to deliver very high power into very low-impedance loudspeakers. In either case, **BE SURE TO REPLACE THE AC Fuse ONLY WITH AN EXACT REPLACEMENT FUSE.** The proper fuse values are:

	<u>Fuse Rating</u>	<u>BUSS®</u>	<u>Littlefuse®</u>
For 115 volt operation	15 Amp 250 Volt	ABC-15/250V.....	(3AG) 314015/250V
For 230 volt operation	8 Amp 250 Volt	AGC-8/250V	(3AG) 312008/250V

WARNING

Before attempting to replace a blown fuse, be certain to unplug the AC Power Cord from the AC wall outlet to prevent possible electrical shock.

Replace the AC Fuse *only* with one identical in type and rating as printed on the rear panel. **DO NOT USE ANY SUBSTITUTE FUSES WITH DIFFERENT RATINGS OR VALUES.** Failure to observe this precaution may cause serious damage to the amplifier circuits, **MAY CREATE A FIRE HAZARD, AND MAY VOID THE WARRANTY.**

If the Power LED (●) does not glow, it may be an indication that the AC fuse has blown. If you are not sure, or the amplifier displays other symptoms, please consult the **RESOLVING PROBLEMS** section on page 11. To remove the fuse-holder cap, you will need a ¼" standard flat-blade screwdriver. Place the screwdriver in the recessed slot in the cap. Turn the cap 1/8-turn counter-clockwise (to the 10:30 position), until the cap pops out towards you. Grasp the cap with your fingers and pull it completely out. The fuse is inserted in the back of the cap; gently pull it free. Since the fuse has a ceramic body, you cannot visually examine the fuse element, it is therefore suggested that you replace it with an identical substitute or bring the fuse to your Adcom dealer so they may check its integrity. To replace the fuse, insert it in the back of the fuse-holder cap. Place the cap into the fuse-holder with the arrow 1/8 -turn to the left of center (10:30 position). Place the screwdriver in the recessed slot, gently press in and turn 1/8-turn clockwise (to the 12 o'clock position)

⑤ AC Power Cord

The AC cord provides power to operate all the GFA-7000's circuits. Its plug can be connected to a standard wall outlet provided the outlet supplies a voltage compatible with the power requirements printed on the rear panel of the GFA-7000.

The GFA-7000's power cord is supplied with a "polarized" AC plug as required by UL/CSA standards and the National Electrical Code. To minimize the risk of electrical shock and to insure minimal hum from the system, do not defeat the polarity insuring feature of the plug (one wide blade and one narrow blade). To prevent electrical shock, do not use this polarized plug with an extension cord or AC outlet unless the blades can be fully inserted to prevent blade exposure.

FRONT PANEL

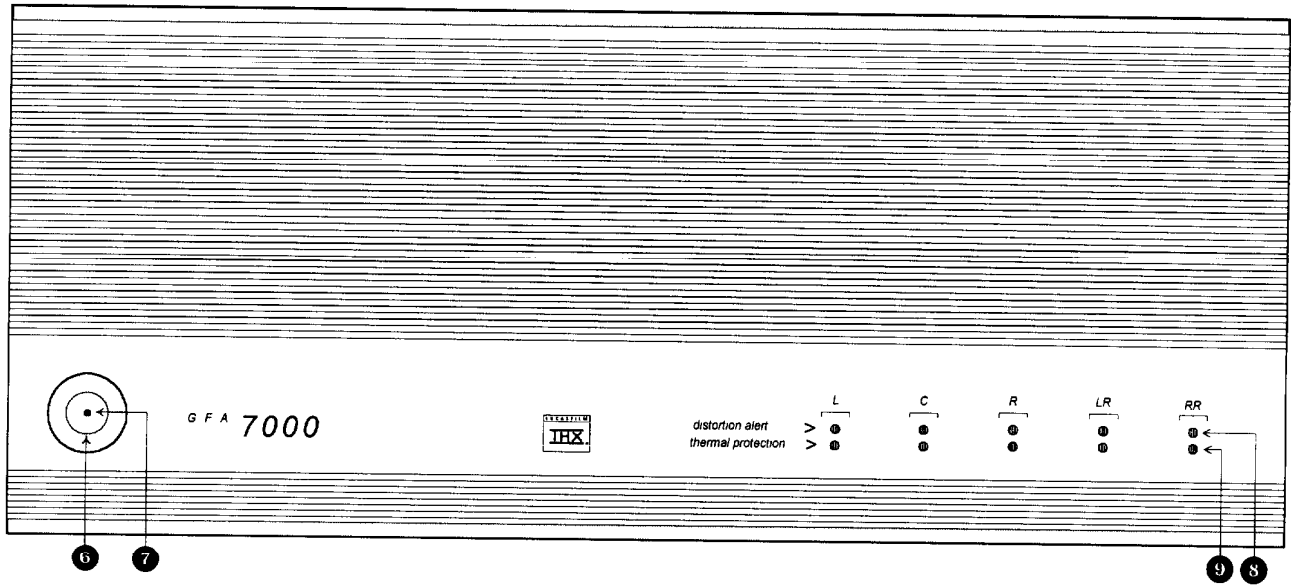

6 On/Off Switch

The On/Off Switch controls power to the power transformer and circuits of the GFA-7000. Whenever the GFA-7000 is energized the Power LED (7) will glow. To turn the GFA-7000 on, press the push-button. It will remain in the “engaged” position while the unit is energized. To turn the GFA-7000 off, press the push-button in and release and it will move to the “disengaged” position.

7 Power LED

This LED will glow whenever the On/Off Switch (6) is turned on and the GFA-7000 is energized. The Power LED indicates that there is AC voltage being fed to the amplifier, but it does not signify that all the amplifier’s circuits are in operation. If, for example, one of the Thermal Protection LED (9) glows, that amplifier channel will not produce sound even though the Power LED may still glow. When the GFA-7000 is turned off, the Power LED will take some time to fade out completely. It may take up to 30 seconds to fully extinguish.

Additionally, the internal power transformer is provided with a thermostat which will interrupt power into the transformer if its temperature exceeds 125°C. This high temperature will seldom, if ever, be encountered unless the amplifier is subjected to abnormal conditions, such as operation into loads of less than 3 ohms at very high listening levels, etc. If the AC Fuse (4) is not blown, the Power LED is out, and the Thermal Protection LED (9) does not glow, this would indicate that the thermostat within the transformer has opened.

Once the temperature within the transformer decreases to a normal level, the thermostat will reset itself automatically and normal operation will resume. If you are to avoid continually tripping the thermostat in the transformer, you must reduce the sound level demands, correct the load impedance of the loudspeakers, or both.

④ Distortion Alert LEDs

The Distortion Alert circuit is a unique ADCOM distortion detection system which reads all forms of non-linear distortion such as THD, IM, slew-induced, “clipping”, etc. The Distortion Alert LEDs will light when distortion reaches 1% regardless of impedance, voltage/current phase angle or the reactance of the loudspeakers which the amplifier is driving. Sometimes, when the amplifier is in use, the LEDs may occasionally flicker during high volume listening, particularly if you are driving low impedances. This flickering is no cause for concern. The LEDs are simply warning you that the amplifier is approaching its maximum power output into the particular loudspeakers you are using. If, however, the Distortion Alert LEDs glow brightly or are illuminated most of the time during playback, you are overdriving the amplifier and should turn down your volume control to reduce the listening level, otherwise it may cause the Thermal Protection to be activated or, in extreme cases, damage your loudspeakers.

⑤ Thermal Protection LEDs

The GFA-7000 is provided with a thermal protection circuit which will shut down the individual amplifiers if its heatsink temperature reaches 85°C. The Thermal Protection LEDs will light whenever the thermal protection circuit on its respective channel has been triggered and the amplifier is inoperative. The thermal protection circuitry will typically be triggered by very high power demands into impedances much lower than the amplifier is capable of driving at those levels. If any amplifier channel's output through the loudspeaker(s) ceases abruptly, and its Thermal Protection LED glows, you will know that its heatsink temperature has become unacceptably high and the circuitry is protecting the amplification devices. Please note that the Power LED (④) will remain on and the amplifier will still be energized. Once the temperature of the heatsink(s) drops to a safe operating level, that amplifier will automatically resume operation.

Activation of the Thermal Protection circuitry in any of the amplifiers in the GFA-7000 is an indication that the amplifier has been overdriven or that the load the loudspeakers are presenting to the amplifier is unreasonably low. If you wish to prevent recurrent activation of the thermal protection circuitry, you must reduce the volume-level demands or correct the load-impedance condition which may be causing activation of this circuitry.

INSTALLATION & HOOKUP

UNPACKING THE GFA-7000

Before your new GFA-7000 left our factory, it was carefully inspected for physical imperfections and tested for all electrical parameters as a routine part of ADCOM's systematic quality control. This, along with full operational and mechanical testing, should ensure a product flawless in both appearance and performance. After you have unpacked the GFA-7000, inspect it for physical damage. Save the shipping carton and all packing material as they are intended to reduce the possibility of transportation damage, should the amplifier ever need to be shipped again. In the unlikely event damage has occurred, notify your dealer immediately and request the name of the carrier so a written claim to cover shipping damages can be initiated. **THE RIGHT TO A CLAIM AGAINST A PUBLIC CARRIER CAN BE FORFEITED IF THE CARRIER IS NOT NOTIFIED PROMPTLY IN WRITING AND IF THE SHIPPING CARTON AND PACKING MATERIALS ARE NOT AVAILABLE FOR INSPECTION BY THE CARRIER. SAVE ALL PACKING MATERIALS UNTIL THE CLAIM HAS BEEN SETTLED.**

PLACING THE GFA-7000

During normal home operation the internal heatsinks of the GFA-7000 may become warm. However, there are instances during high-level playback into low impedances when the heatsinks will become much warmer than usual. To ensure the amplifier's long-term, trouble-free operation it is necessary to provide adequate ventilation for the heatsinks. Therefore, the GFA-7000 should be kept away from external sources of heat such as radiators and hot-air ducts. **The GFA-7000 should never be placed with other heat-producing components in a cabinet or enclosure lacking free air flow.** The top and bottom panel of the amplifier's chassis have been provided with vents to allow the necessary cooling of the internal components. It is imperative that these vents are not obstructed in any way.

We recommend that you do not stack other components on top of the GFA-7000. This is particularly important if your system includes low-impedance loudspeakers which are difficult to drive, or if you will consistently demand high volume levels from the amplifier and speaker system. Not only will heat generated by the amplifier affect the performance of equipment stacked on top of the GFA-7000, but the free flow of air through the ventilating slots in the amplifier may be partially obstructed.

If you observe these recommendations, the GFA-7000 will perform reliably in any reasonable environment. You should also pay attention to such normal considerations as protection from excessive dust and moisture. Occasional vacuuming of accumulated dust on the chassis, panels and around the ventilating slots should be all that is required.

The optimal performance of your new GFA-7000 will ultimately depend on the care with which you make the connections between the amplifier, preamplifier, surround sound decoder and the loudspeakers. All input and output signal connections should be made only with high quality, low-loss, low capacitance cables following the recommendations in the **Inputs and Outputs** section of **CONNECTING THE GFA-7000**.

QUICK CONNECTIONS

For those of you who are in a hurry to hook up your amplifier into your system, we have included this quick-connection section. The wiring is straight forward and expeditious if you use the proper cables and follow this diagram exactly. If you have any difficulties or questions, please refer to the appropriate section of this manual for complete descriptions and instructions.

WARNING

Whenever connections to or from the GFA-7000 are being made, be certain that the AC On/Off Switch (Ⓢ) of the amplifier is in the OFF position, the AC Power Cord (Ⓢ) of the amplifier is disconnected from the AC wall outlet and that all associated components are turned off.

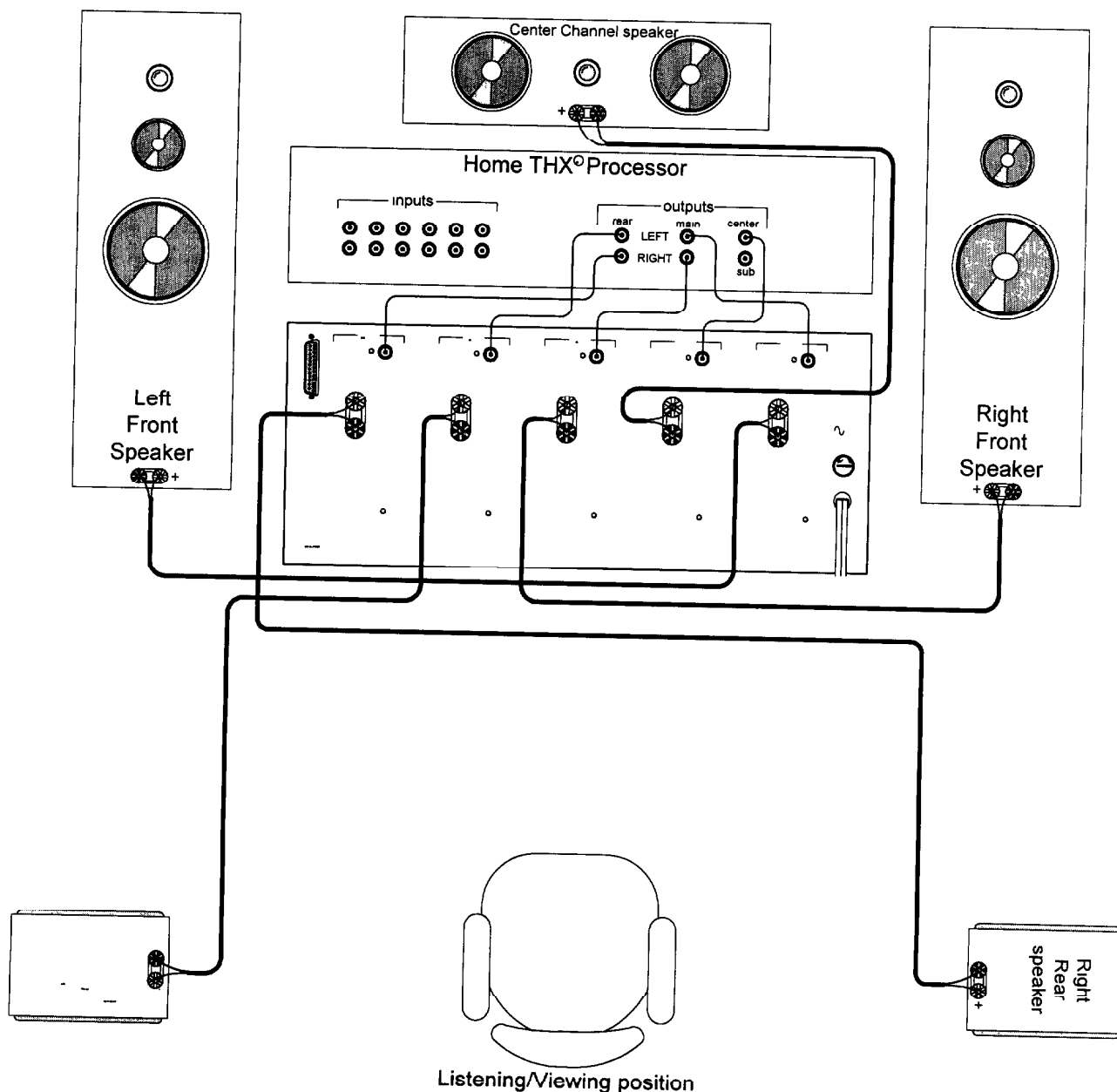

CONNECTING THE GFA-7000

Remember, that the Left and Right designations are *as you are sitting down in your listening/viewing area*. On the rear panel, the inputs and outputs are grouped in 5 bracketed sets, one for each channel. They are abbreviated as indicated:

RR..... Right Rear
LR..... Left Rear
R.....Right
C..... Center
L..... Left

① Inputs:

To preserve the correct effects, be certain to connect the RCA cables to the proper RCA-input connector. If the cables are color coded, then use this sequence for the connections:

Blue Left(L)
Red..... Right(R)
Green Center(C)
White with Blue Stripe Left Rear(LR)
White with Red Stripe..... Right Rear(RR)

Home THX® certified RCA cables will have directional arrows printed on the side of each cable. Make certain that these arrows are pointed *towards* the GFA-7000. The recommended maximum RCA cable capacitance should be *less than or equal to* 30pF per foot when measured between the two conductors, and *less than or equal to* 50pF per foot when measured between one conductor and the shield.

With the DB-25 computer-type Multichannel input connector(Ⓢ), there is no need to worry about color coding or properly connecting the RCA plugs, as this is done in one connector with one cable. The DB-25 can easily transfer all five channels from the output of the Home THX® processor unit to the input of the GFA-7000 amplifier. There can be no errors with the DB-25, it is shaped so that it can only be connected in the proper direction. Contact your dealer to locate a THX® DB-25 signal cable.

② Outputs:

NOTE:

The GFA-7000 is "polarity correct". That is it does *not* invert phase from input to output. Any positive signals at its inputs will appear as a positive signal at its outputs

In connecting the amplifier to the loudspeaker, it is vital to maintain proper polarity (positive to positive, negative to negative). On the GFA-7000, the positive terminal is color coded RED and labeled "+", and the negative is color coded BLACK and labeled "-". The positive terminal on the speaker will be color coded RED, or will be labeled "+", "pos", "positive", "8 ohms", or "4 ohms". The negative terminal on the speaker will be color coded BLACK, or will be labeled "-", "neg", "negative", "C", "Common", "G", or "ground".

It is recommended by the Home THX® standards that your speaker cables be terminated with "U" type spade connectors. These will give the most contact area insuring long-term reliability. The spade connector should have a maximum width of 0.57 inches and an opening width of no less than 0.25" (see diagram on right).



To properly connect the speaker cable to the binding posts, turn the insulated head of the binding post clockwise until the wire or connector is firmly secured. Finger pressure is sufficient and you should not use pliers or other tools which could damage or over-tighten the binding-post assembly. The binding posts, have been designed in such a way that finger pressure is all that is required to cause a “pinching” action among the different metal surfaces to ensure proper connection.

It is very important to use the correct size of wire in order to avoid unnecessary loss of amplifier power in the cable, reduction of amplifier damping factor and other undesirable conditions. Home THX® specifications require the use of at least AWG16, stranded, copper cable. Recommended capacitance of the speaker wire should not exceed 50pF per foot. This insures high frequencies will not be rolled-off.

It is suggested that the *three front channels* follow this chart for speaker lengths and wire gauges. These recommendations are standardized Home THX® performance specifications.

up to 24 feet	AWG16
up to 36 feet	AWG14
up to 58 feet	AWG12

Generally, for the *two rear surround channels*, longer runs of cable are needed, but since less program material is being transmitted through the cable, longer runs are acceptable:

up to 48 feet	AWG16
up to 72 feet	AWG14
up to 116 feet	AWG12

If longer runs are needed, it is best to consult with your Adcom Dealer to maximize the performance of your system with your exact conditions.

All loudspeakers having a nominal impedance down to 4 ohms can be connected to and driven by the GFA-7000. The amplifier can drive these low-impedance speakers at more than adequate power levels with no difficulty. It should be noted here that many loudspeaker systems which are nominally rated at 4 ohms drop in impedance, in some parts of their frequency range, to as low as 2 ohms (and sometimes less). You will not experience difficulties even with these very low impedance loads unless you demand excessively high volumes levels from your system.

It is not recommended that you run additional sets of speakers on any or all of the amplifiers in the GFA-7000 in order to insure the integrity of a Home THX® system. If you choose to add remote speakers in another room, it is strongly suggested that a switching system to disconnect the non-home-theater speakers be incorporated when the surround sound, home-theater mode is in operation. A device such as the Adcom GFS-3, GFS-4 or GFS-6 Speaker Selector is strongly recommended. A Speaker Selector enables you to maintain Home THX® integrity while giving you the flexibility to add speakers throughout your house.

CARING FOR YOUR GFA-7000

Great care has been taken by ADCOM to ensure that your amplifier is as flawless in appearance as it is electronically. The front panel is a heavy-gauge, high-grade aluminum extrusion carefully finished and anodized for durability. The chassis, top cover and rear panel are heavy-gauge steel that has been powder coated and baked to ensure a lasting finish. If the front panel, top or sides become dusty or fingerprinted, they can be cleaned with a soft lint-free cloth, slightly dampened with a very mild detergent solution or glass cleaner. **DO NOT SPRAY OR POUR LIQUIDS OF ANY KIND ON THE GFA-7000.**

TROUBLESHOOTING

RESOLVING PROBLEMS

Use the chart below to solve common situations that don't require professional attention. If the steps stated in POSSIBLE SOLUTION do not resolve your problem, then please contact your Adcom Dealer or call the Adcom Customer Service Department. Any problems not covered here should be brought to the attention of your Adcom Dealer or Adcom Customer Service Department.

A special note on "hum" : When there is a low-volume "hum" audible throughout your speakers, even with the main volume turned all the way down, you have a common phenomenon known as a "ground loop". A ground loop is basically a difference in ground voltages between two or more components which are connected electrically and which creates multiple current paths where there must only be one. This difference in potentials creates a 60Hz low-level sound (approximately a low A#), that seems to "hum", hence the name.

It can be caused by adding new components to your system, but that does not imply there is anything electrically wrong with any new component. With the advent of audio/video and home theater systems, the problem has become commonplace. Generally, the cause is the Cable-TV incoming signal line. This new incoming line may add an additional ground at a different potential to the AC line ground of your other equipment (refer to *Note 1* and *2* below to troubleshoot a hum problem).

SYMPTOM	POSSIBLE REASON	POSSIBLE SOLUTION
Power LED does not glow No sound	AC Power Cord(⚡) not plugged in.	Plug in AC Power Cord(⚡).
	AC Fuse(⚡) blown.	Replace AC Fuse(⚡).
	Transformer thermal protection engaged	Wait until unit cools down. it will reset.
Power LED glows, but no sound	Preamp or source unit is not on	Make sure whole system is on.
	Connections in rear of amp are loose.	Verify all connections on rear of amp
One channel not producing sound	INPUT(⚡) or OUTPUT(⚡) connector disconnected or loose.	Verify both connections on that channel
	Speaker disconnected.	Verify connection at speaker.
	Internal protection engaged	Bring to Dealer or Service Center
Hum from all speakers at any volume	Ground loop (difference in ground voltages between components).	If Cable TV is present (see <i>Note 1</i>) If Cable TV is not present (see <i>Note 2</i>)
Hum from all speakers (hum goes up or down with volume)	Problem with source unit (CD, tape, etc.), or RCA cable connecting that source unit to the preamp.	Try different source (tuner, tape, etc) and/or different RCA cable
Hum from the amplifier itself	Some major appliance, dimmer, halogen or fluorescent light is creating interference	Make sure all appliances, dimmers and suspect lights are off

Note 1 Cable TV systems can sometimes contribute to ground loop problems which cause "hum" To determine if your cable system is the contributing factor, disconnect the Cable-TV incoming signal line (round, 75Ω) at the wall, or the first component the cable is connected to (i.e. the cable box, or VCR) If the hum is no longer present, you must insert a "75Ω Ground Loop Isolator" before reconnecting the line. You should check with your Adcom Dealer to obtain one. If the "75Ω Ground Loop Isolator" works only partially or not at all, then please read *Note 2* to complete the troubleshooting procedure

Note 2 Make sure that the power amplifier is at least 6" from the Preamp and/or Processor. Usually putting another component between them is sufficient to minimize the hum If this does not reduce the hum, turn the system off and disconnect all Inputs from the amplifier. If the hum still persists, then your Dealer or Service Center must examine the amplifier. If the hum disappears, try another set of RCA cables. Connect one RCA cable at a time to see if one specific cable is responsible. If any or all cables cause the hum to appear, then the preamp or processor should be evaluated for proper operation by your Dealer or Authorized Service Center.

SERVICING

ADCOM has a Technical Service Department to answer questions pertinent to the installation and operation of your unit. In the event of difficulty, please contact us for prompt advice. Please have the following information readily at hand: the unit's model and serial numbers, and dealer from which it was bought. If your problem cannot be resolved through our combined efforts, we may refer you to an authorized repair agency, or authorize return of the unit to our factory. To aid us in directing you to a convenient service center, it would be helpful if you indicate which major city is accessible to your home.

Please address mail inquiries to:

ADCOM Service Corporation
11 Elkins Road
East Brunswick, NJ 08816
USA

Phone or Fax inquiries to:

Voice: 908-390-1130
Fax: 908-390-9152
Monday through Friday
9:00 AM to 5:00 PM Eastern Time

UNDER NO CIRCUMSTANCES SHOULD YOUR UNIT BE SHIPPED TO OUR FACTORY WITHOUT *PRIOR AUTHORIZATION*, OR PACKED IN OTHER THAN ITS ORIGINAL CARTON AND FILLERS.

For fax inquires, please include a return fax or voice number for the reply. When calling or writing about your GFA-7000, be sure to note and refer to its serial number as well as the date of purchase and the dealer from whom it was purchased. In the event the unit must be returned to our factory for service, you will be instructed on the proper procedure when you call or write for a Return Authorization. For warranty coverage, a copy of the original proof of purchase is required. If you have no original copy, please contact your dealer to obtain a duplicate copy.

If the original shipping carton and its fillers have been lost, discarded, or damaged, a duplicate carton may be obtained from our Service Department for a nominal charge.

Always ship PREPAID VIA UNITED PARCEL SERVICE (UPS) OR OTHER APPROVED CARRIER. DO NOT SHIP VIA PARCEL POST, since the packing was not designed to withstand rough Parcel Post handling. FREIGHT COLLECT SHIPMENTS CAN NOT BE ACCEPTED UNDER ANY CIRCUMSTANCES.

GFA-7000 SPECIFICATIONS

Power Rating (To FTC Requirements)

130 watts continuous average power into 8 ohms at any frequency between 20Hz to 20kHz with all channels driven at less than 0.05% THD

200 watts continuous average power into 4 ohms at any frequency between 20Hz to 20kHz with all channels driven at less than 0.05% THD

IM Distortion (SMPTE)

1 watt to 130 watts into 8 ohms. ≤ 0.05%
 1 watt to 200 watts into 4 ohms. ≤ 0.05%

IM Distortion (CCIF, Any Combination from 4kHz to 20kHz)

130 watts into 8 ohms ≤ 0.02%
 200 watts into 4 ohms ≤ 0.02%

THD + Noise at 130 watts into 8 ohms (Typical)

20Hz 0.0075%
 1kHz 0.007%
 10kHz 0.015%
 20kHz 0.025%

THD + Noise at 200 watts into 4 ohms (Typical)

20Hz 0.015%
 1kHz 0.010%
 10kHz 0.022%
 20kHz 0.035%

Frequency Response @ 1 Watt into 8 ohms (10Hz to 20kHz) +0, -0.25dB

Power Bandwidth (-3dB) 15Hz to 100kHz

Dynamic Headroom into 4 ohms 19 dB

Signal to Noise Ratio, "A" Weighted (130 watts into 8 ohms) ≥ 115dB

Gain 29dB

Input Sensitivity

for 1 Watt 0.1 volts
 for 130 Watts 1.14 volts

Input Impedance 50kΩ

Damping Factor (20Hz to 20kHz) ≥ 800

Rise Time (5kHz, 90V, peak-to-peak square wave, 20% to 80%) 2.7μS

Power Consumption (Continuous, All Channels Driven)

Quiescent 80VA
 Maximum 1440VA
 130 watts into 8 ohms 1200VA

Power (Available in 230VAC on special order) 115VAC - 50/60Hz

Chassis Dimensions 7" (178mm) x 17" (432mm) x 13 3/4" (349mm)

Maximum Dimensions 7 3/8" (187mm) x 17" (432mm) x 14 7/8" (378mm)

Weight 41 lb (18.6 kg)

Weight, Packed 46 lb. (21.3 kg)



11 Elkins Road
East Brunswick, NJ 08816
USA
Tel: (908) 390-1130
Fax: (908) 390-9152