

Haydn Grand

General



Haydn's music is known for its lyricism, from which vibrant tonal colors and brilliant harmonic structures are drawn out of deceptively simple arrangements. Similarly, the Haydn Grand's deceptively simple driver complement of a 6" X3P mid-bass driver and refined 1" triple stacked silk-dome tweeter centers around the groundbreaking airflow control wedge bass reflex port (also found on the Bach Grand) that serves to virtually eliminate port noise, allows for increased placement flexibility, and provides an extraordinarily compact driver configuration by positioning the tweeter on the front of the wedge. This combination of elements, housed in a beautifully compact cabinet, permits equally effective and effortless placement in either bookshelves or on speaker stands. A compact 2-way monitor, Haydn Grand features exceptional imaging, resolution and linearity, challenging the performance of the finest floor standers.

Handcrafted enclosures in beautiful wood finishes define the Vienna Acoustics aesthetic. The Grand Series features the following selections to complement any interior: Piano black, Maple, Cherry, and Rosewood.

Haydn Grand

Features



Most notable of the many unique technological features found in the Haydn Grand is the ground-breaking bass reflex port air-flow control wedge. Not only does this assembly allow for a front port configuration that increases placement flexibility, by virtually eliminating port noise, but it also provides an extraordinarily compact driver arrangement by positioning the tweeter on the front of the wedge. Both features contribute to an unrivaled level of performance in its class.



The unique construction works by way of an inner reflex port that vents air towards a wedge positioned at the throat of the port. The cutting-line of the wedge divides the airflow into two streams, which then flow in a specially designed and extensively optimized flare. The relationship of the wedge and the flare is of critical importance, and are precisely determined to achieve a) maximum bass support for the system and b) the reduction of all standing waves in the port (or port noise) by -12dB .



The wedge fulfills additional and very welcome functions in the design. As mentioned above, the large size of the wedge allows the tweeter to be mounted within the throat of the port, resulting in a very compact driver arrangement that improves phase coherency and overall performance by creating a near point-source configuration. In addition, the large internal volume allows for a chamber to vent the back-wave of the driver. To optimally use the chamber, a unique circular back wave pass through slot runs the entire circumference of the back of the driver, as opposed to a central hole. Because of this feature, the specially designed tweeter for this assembly profits from unconstrained air-decompression that approaches the theoretically ideal conditions of free-field construction. As a result, the tweeter dome operates unconstrained, even as it descends into the lower midrange.

The entire assembly is constructed of aluminum, produced by expensive high pressure die-cast tools.



As with all Vienna Acoustics loudspeakers, a handcoated silk dome tweeter was specifically designed, featuring a specially developed ferrofluid damping system in combination with a super-light four ohm voicecoil, for superior resolution of high frequency extremes while achieving perfect midrange warmth and clarity.

Haydn Grand

Features



The new 6" midrange driver benefits from a reformulation of Vienna Acoustics' proprietary XPP cone material. Combining TPX, the unique thermoplastic used in all XPP cones, with three polypropylene based synthetics achieves maximum inner damping, ultra-low mass, and precise control over cone density and rigidity. Dubbed X3P (X3P because of the three additional polymers in its composition) this new cone material allows the driver to provide an extraordinarily wide bandwidth, while possessing a level of inner detail, quietness, and control that is truly remarkable.

The mid-bass driver benefits from a new inverted rubber surround design that constitutes a breakthrough in no loss damping of cone edge resonances.



A completely new linear crossover layout, with the copper circuit paths arranged in the direction of electron flow, takes into account the potential for sympathetic and parasitic interactions among crossover components that may inject unwanted noise and distortions while allowing for more direct and efficient transfer of signal to the drivers which leads to a greater level of detail and purity.

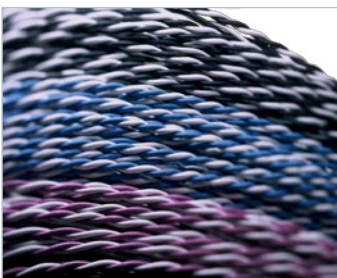

New proprietary cabling, consisting of large scale solid copper conductors, with each cable pairing precisely twisted a prescribed number of turns for the particular length of each cable so that any noise injection through the wiring harness is avoided.

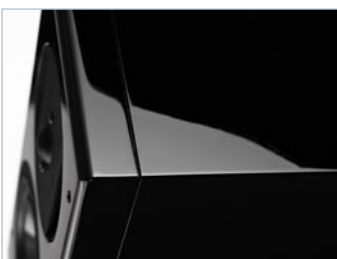

Cabinets boast massive baffles that are 1.25" thick, 25% thicker than previous models, for maximum rigidity and resonance control.

Maple and Cherry finishes join a revised Rosewood, applied to the highest of standards using the state-of-the-art veneer-wrapping technology for the front and rear baffles first pioneered on the Classic series. A true Piano Black lacquer is now available, the quality of which will permit inclusion into any living room as it mirrors its surroundings.

Haydn Grand

Features



New gold-and-silver alloy terminal for lowest transfer resistance and durability are directly connected to the crossover circuit board to ensure complete current delivery and no loss of clarity in the signal transfer from binding post to crossover.



Innovative and unique grilles feature an aluminum frame that incorporates an integral V-shaped phase diffuser to control dispersion so that they can be left on for all but the most critical listening without an adverse influence on performance. In fact, it can be used as an additional tuning device for the audio enthusiast, benefiting soundstage presentation both in depth and stereo imaging. As an additional benefit, the V-shaped groove running the length of the middle of the grille results in a more elegant appearance for the speaker.



HAYDN Grand is 100% shielded

Haydn Grand

Specs

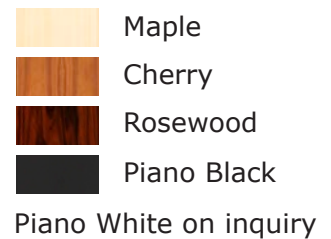
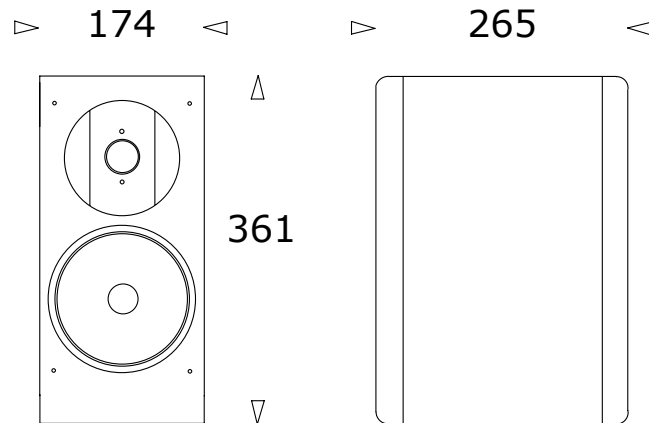

Impedance
Frequency Response
Sensitivity
Recommended Amplifiers Drive Units
5" Bass/Midrange Driver
1 " Dome-Tweeter
Bass System
Bass Function
Crossover Components

Crossover Function
Weight per Pair
Dimension (W x H x D) inches
Dimension (W x H x D) mm

4 Ohms
 42-20000 Hz
 89 dB
 25 - 180 Watts
 X3P Cone, Transparent
 Hand-coated VA Silk Dome
 Bass Reflex, Frontported
 Impulse Optimizing QB 3 (Quasi-Butterworth)
 MKP Capacitors 1% Tolerance
 Coils 0,7% tol., Exclusively Air Coils
 Metal Film Resistors, 1% tol., Inductance Free
 2-way, 6 dB and 12 dB Bessel
 44 Ibs / 20 kg
 6,85 x 14,2 x 10,4"
 174 x 361 x 265 mm

Optional bookshelf stand available.

Contact:
 Vienna Acoustics
 Rysergasse 60
 A - 1230 Wien - Vienna
 AUSTRIA

Phone: +43 (0)1 88 96 815
 Fax: +43 (0)1 88 96 599
 e-mail: office@vienna-acoustics.com
 Web: www.vienna-acoustics.com